

Contents

General Information.....	WS-2
Epoxy Resin Worksurfaces	WS-4
Greenstone Epoxy Resin Worksurfaces.....	WS-5
Laboratory Grade Phenolic Resin Worksurfaces	WS-6
Solicor-CR (Chemical Resistance) Worksurfaces	WS-7
HPL (High Pressure Laminate) Worksurfaces.....	WS-8
Solid Surface Worksurfaces	WS-9
Maple Butcher Block Worksurfaces	WS-10
Stainless Steel Worksurfaces	WS-11
Typical Bench Sections	WS-12

General Information

Please review the following for Work Surface information. Contact your dealer for any clarifications.

Selection of the proper work surface material is essential for optimum function and durability. Many criteria must be assessed and prioritized before a material is selected. A partial listing of criteria is presented below but additional requirements may also be considered.

Configuration of work surfaces is also very important. Applications for wall-to-wall installations may require large pieces of material with sealed joints, back splashes and end return splashes. For modular or mobile applications, work surfaces may be supplied in small pieces with all edges finished.

Some work surface materials are available in more than one style. Integral splashes, various edge treatments and molded or machined recesses for containment are some of the variations possible.

Some of the most common work surface materials are described in this section. Other materials, such as solid surfacing material, natural stone, electrostatic dissipative materials and ceramics are also available. Consult your CiF Lab Solutions representative for more information and assistance.

Selection Criteria:

- | | |
|---------------------|-------------------|
| abrasion resistance | heat resistance |
| chemical resistance | impact resistance |
| color | porosity |
| conductivity | stain resistance |
| decontamination | vandal resistance |
| hardness | water resistance |

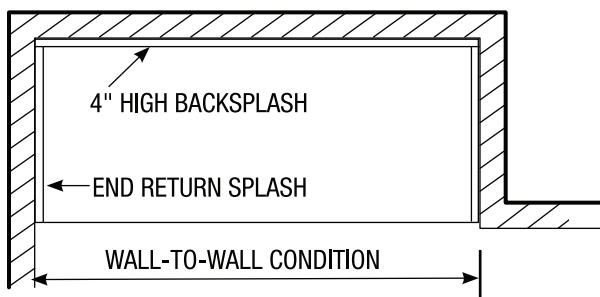

When working with wall-to-wall conditions, work surfaces require a finished edge on the front only. It is necessary to confirm that dimensions are consistent at both the front and rear of the tops and that adequate clearance is allowed for placement of the work surface(s). Backsplashes and end returns can be used as trim pieces for containment and aesthetics.

General Information (cont.)

Work surfaces which will be used for island configurations must be finished on all four edges. Dimensions for island work surfaces should include an equal overhang on all four sides (nominally one inch). Back splashes are not generally used in island configurations. Work surfaces for peninsulas are usually finished on three sides.

ISLAND WORK SURFACE
ALL FOUR EDGES FINISHED

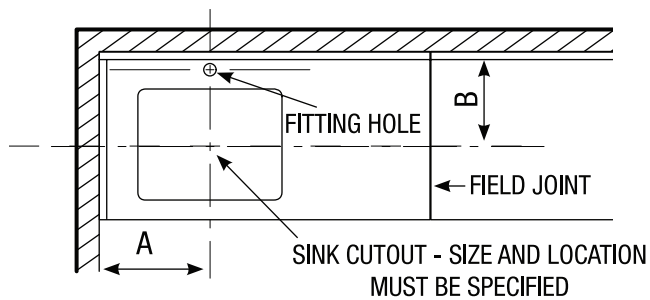

Sink sizes, configurations and locations must be clearly indicated. Fitting hole sizes and locations are also necessary. Clearances of sink basins and fittings must be verified in relation to support structures and base cabinets. Placement of work surface joints should not jeopardize the strength or alignment of the finished work surface. CiF does not offer cutouts within laminate tops. For additional information, contact your CiF representative.

Epoxy Resin

Epoxy resin is a monolithic thermosetting material composed of modified epoxy resin and a fine filler material. Liquid resin is poured into molds, which may have special shapes and details such as raised edges or back splashes. After curing, the material exhibits exceptional structural strength and excellent chemical resistance. Finished edges are the same material as the work surface. Thickness is generally 1" and available in standard colors. Refer to our Service Fixtures and Accessories section for a full range of under counter mount and lipped drop-in sinks, along with ADA sinks and cup sinks. See your CiF Lab Solutions representative for color options.

Sizes

Width/depth: Up to 72"

Lengths: Up to 96"

Thickness: 1-1/4", 1" and 3/4"

Edge Profiles

Square Edge (1/8" bevel) and Marine Edge

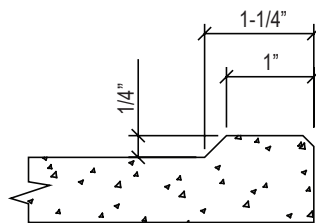

Marine Edge

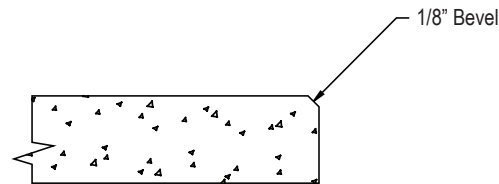

Classic (Standard) Edge

Greenstone Epoxy Resin

Greenstone is an innovative work surface that integrates post-consumer recycled material with lab grade epoxy resin. Greenstone's composition makes it durable with superior resistance to heat, chemicals and stains. Like Epoxy Resin Greenstone composition is homogeneous and monolithic.

Greenstone adds to the sustainability of your lab project.

Sizes

Width/depth: Up to 72"

Lengths" Up to 96"

Thickness: 1-1/4", 1" and 3/4"

Edge Profiles

Square Edge (1/8" bevel) and Marine Edge

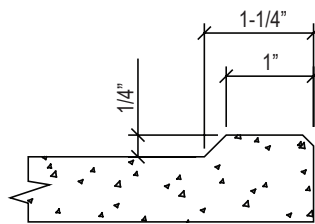

Marine Edge

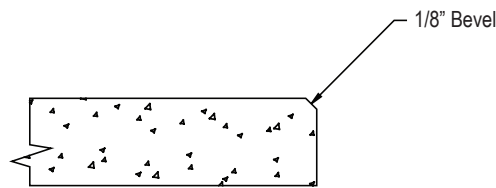

Classic (Standard) Edge

Laboratory-Grade Phenolic Resin

Solid phenolic is a high-pressure, thermoset resin composite, formed throughout the thickness of the panel. The material is non-porous, non-conductive with high impact resistance and superior structural strength. See your CiF Lab Solutions representative for color options.

Sizes

Width/depth: Up to 60"

Lengths" Up to 120"

Thickness: 1", 3/4" and 1/2"

Edge Profiles

Square Edge (1/8" bevel) and Marine Edge

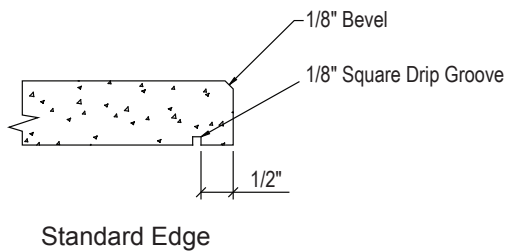

Solicor-CR (Chemical Resistance)

Solicor-CR is a color-through lab grade work surface that offers superior performance where chemical resistance and durability are paramount. Solicor-CR unique color-through core offers unparalleled aesthetics and offers a modern looking alternative to traditional lab grade worksurfaces.

Solicor-CR is non-porous, non-conductive with high impact resistance and superior structural strength.

Sizes

Width/depth: Up to 60"

Lengths" Up to 120"

Thickness: 1", 3/4" and 1/2"

Edge Profiles

Square Edge (1/8" bevel) and Marine Edge

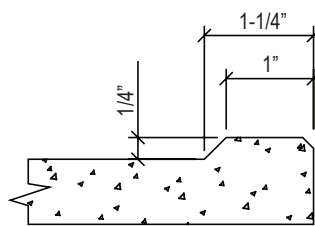

Marine Edge

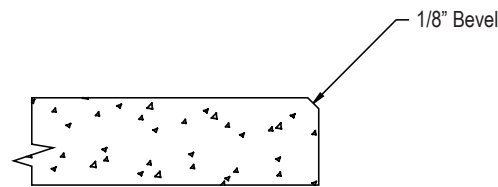

Classic (Standard) Edge

HPL (High Pressure Laminate)

Plastic Laminate

Plastic laminate work surfaces are available in hundreds of colors. The high-pressure plastic laminate is securely bonded to a solid substrate and then fully backed for balanced construction. Nominal thickness is 1". The surface has reasonable chemical resistance to a wide range of acids, alkalis and solvents, with good stain and impact resistance. Durable, impact resistant 3mm PVC edges are machine applied utilizing water-resistant hot-melt adhesive and radiused at the top and bottom edges. Back and return splashes are separate and field applied.

Chemical Resistant Plastic Laminate

Utilizes the same construction as the standard plastic laminate work surface, but incorporates a plastic laminate surface with enhanced chemical resistance characteristics. Fewer color options are available.

Particleboard is available in nominal 1-1/2", 1", 3/4" thickness

Plywood is available in nominal 1", 3/4" thickness

Available edges include 3mm PVC, High-Pressure Self-Edge and Wood Edge

(See note below for variations and differences)

Joinery: Tight Joint Fasteners

Corner Conditions: Butt Joints or Miter Joints

Back and return splashes are separate and field applied

Optional Wood Edge

Can be used only with 1-1/2" buildup and 1-1/8" solid core tops

Available wood types: Oak and Maple; other species on request

Finishes: stain or clear coat

Wood Edge Options

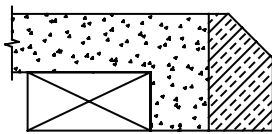

BEVELED EDGE FRONT
Sharp wood corners are eased

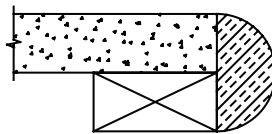

BULLNOSE EDGE FRONT

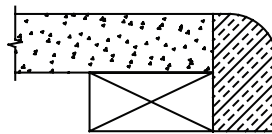

RADIUSSED EDGE FRONT
Sharp wood corners are eased

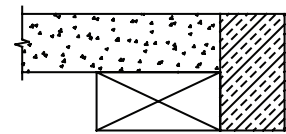

SQUARE EDGE FRONT
Sharp wood corners are eased

Solid Surface

Solid Surface work surfaces are homogeneous and uniform in color throughout the entire thickness of the panel. Solid surface work surfaces do not support fungal or bacterial growth and are stain resistant. Ideally suited for areas with high traffic and/or shared spaces. Solid Surface work surfaces offer good chemical and heat resistance.

Sizes

Thickness: 1/2"

Edge Type

A wide variety of edge profiles are available. Contact your dealer for details

Maple Butcher Block

Butcher Block Tops are constructed of select kiln dried, clear maple laminated in edge grain strips of not more than 2" in width. Laminated pieces are finger-jointed using a water-resistant glue. Tops are finished with a clear Catalyzed Lacquer finish.

Sizes

Width/depth: 25"

Lengths: 12", 18", 24", 30", 36", 42", 48", 60", 72", 84", 96", 108", 120", 132" or 144"

Thickness: 1 1/2"

Edge Type

Square Edge Profile with 1/8" radius

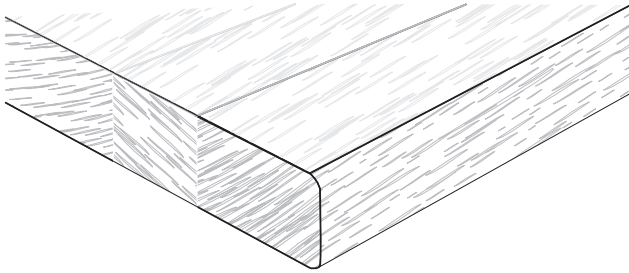

*Shown with Eased Edge

Stainless Steel

Stainless steel work surfaces are ideally suited for areas which require a high level of cleanliness. Tops are custom fabricated using T304 or T316 stainless steel with a #4 finish in 14 or 16 gauge. Countertop cores are particle board reinforcement with sound deadening coating on the underside. A variety of integral sink sizes and sink combinations with drain boards are available.

Edge Type

Marine or square edges

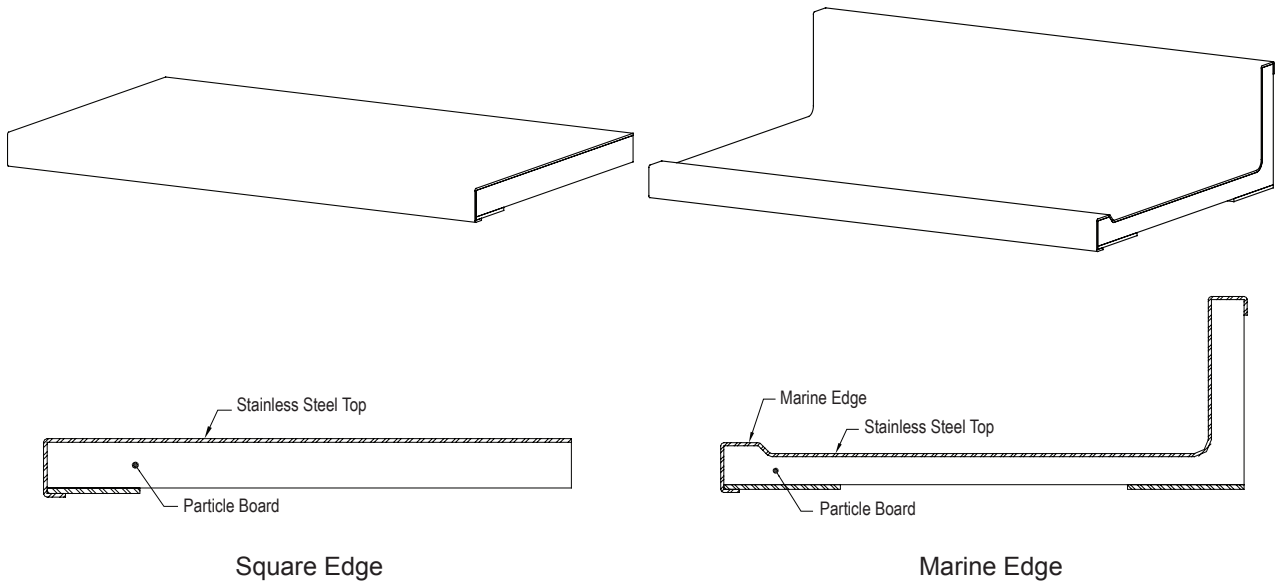

Typical Bench Sections

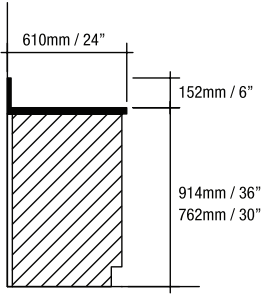
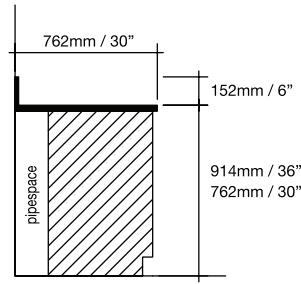
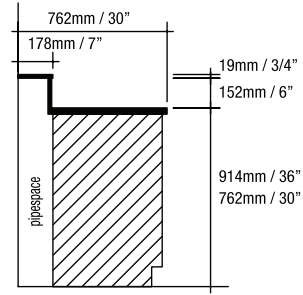
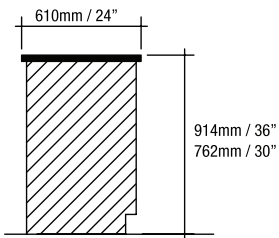
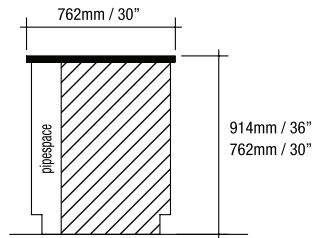
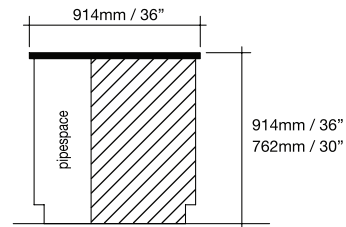
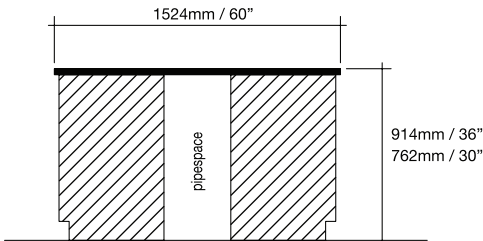
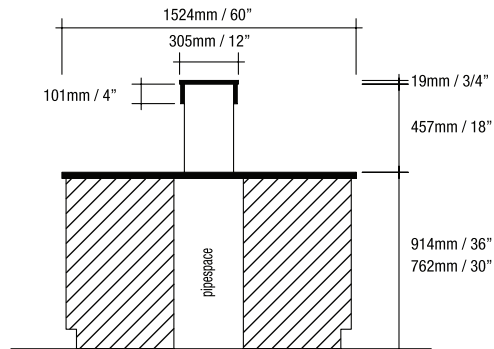
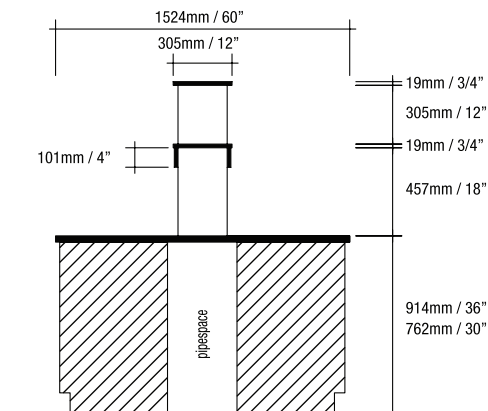
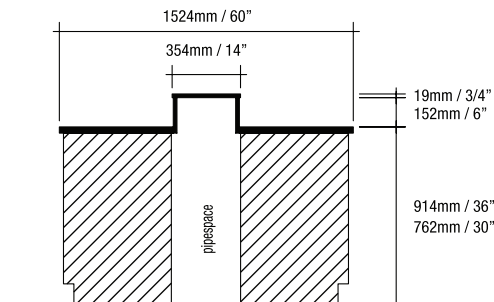
Type 1

Type 2

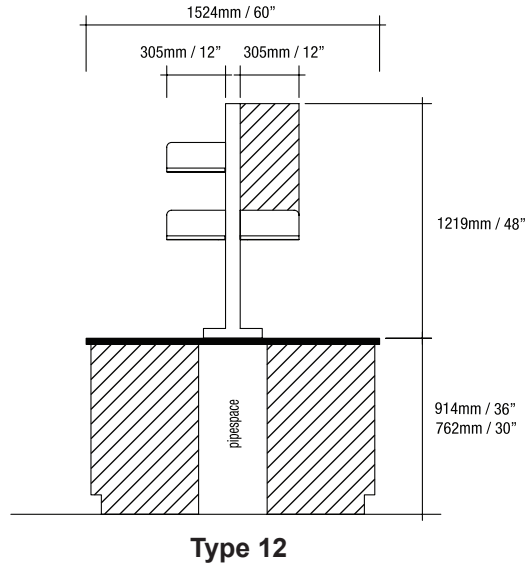
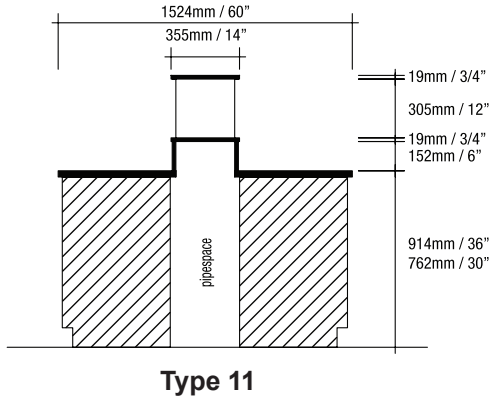
Type 3

Type 4

Type 5

Type 6

Type 7

Type 8

Type 9

Type 10

Typical Bench Sections (cont.)



Work Surfaces Index

General Information	WS-2
Epoxy Resin Worksurfaces	WS-4
Greenstone Epoxy Resin Worksurfaces	WS-5
Laboratory Grade Phenolic Resin Worksurfaces	WS-6
Solicor-CR (Chemical Resistance) Worksurfaces	WS-7
HPL (High Pressure Laminate) Worksurfaces	WS-8
Solid Surface Worksurfaces	WS-9
Maple Butcher Block Worksurfaces	WS-10
Stainless Steel Worksurfaces	WS-11
Typical Bench Sections	WS-12